



Number	Date	Modification	E	Owner
500000535699	12/04/2021			ALISSOBS



CARACTERÍSTICA CRÍTICA
CRITICAL CHARACTERISTIC

PERIMETRO: 1603,900

PERIMETER
PERIMETRO

QUANTIDADE DE FUROS: 0,000

HOLES QUANTITY
CANTIDAD DE PERFORACIONES

AREA: 0,047

AREA
AREA

PLANICIDADE: CURVO

FLATNESS
LLANURA

UNIDADE DO FATOR DE CALCULO: M2

UNIT OF FACTOR FOR CALCULATION
UNIDAD DEL FACTOR DE CALCULO

ALTURA: 725,000

HEIGHT
ALTURA

E M E: VID_004

ENG. MATER. SPECIFICATION
ESPECIFICACION MATERIAL INGENI

E M E: VID_003

ENG. MATER. SPECIFICATION
ESPECIFICACION MATERIAL INGENI

E M E: VID_002

ENG. MATER. SPECIFICATION
ESPECIFICACION MATERIAL INGENI

LARGURA: 77,000

WIDTH
ANCHURA

CODIGO LOGOTIPO: 11458904

LOGO CODE
CODIGO LOGOTIPO

ACABAMENTO BORDA: LAPIDADO

EDGE FINISHING
ACABADO BORDE

FIXACAO VIDROS COLADOS

GLASS ATTACHMENT
FIJACION VIDRIO

COR: FUMEE

COLOR
COLOR

ESPESSURA: 4,000

THICKNESS
ESPESSURA

LADO: JUNTO_A_PORTA

SIDE
LADO

POSICÃO DO MOTOR INDIFERENTE

ENGINE POSITION
POSICIÓN DEL MOTOR

CLP MODELO DE CARROCERIA PARADISO_1800

BODY MODEL CLP
CLP MODELO CARROCERÍA

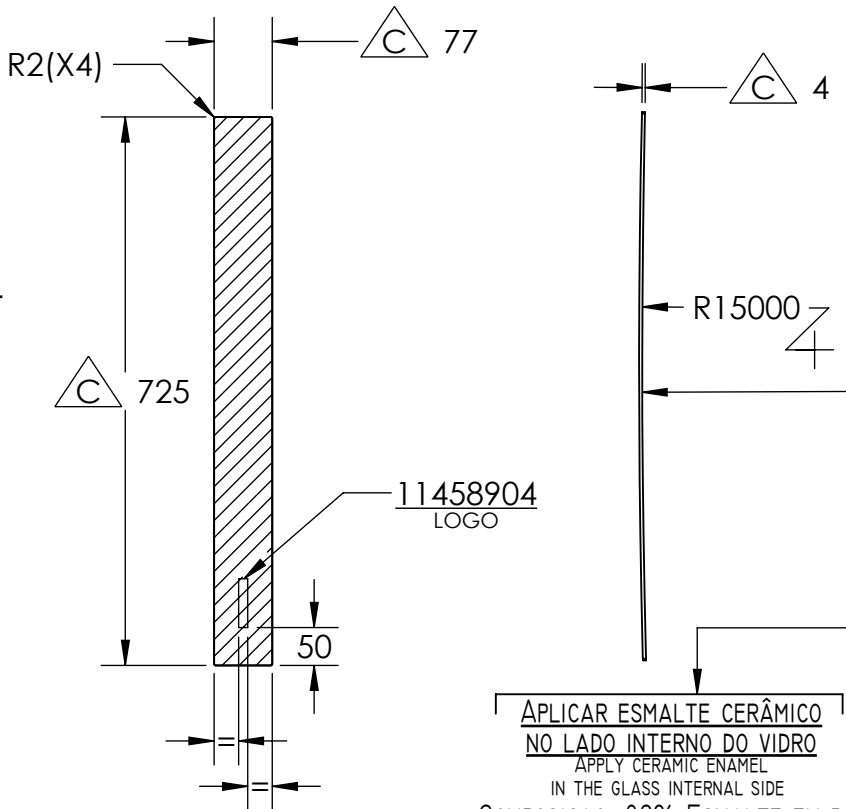

**APLICAR ESMALTE CERÂMICO
NO LADO INTERNO DO VIDRO**
APPLY CERAMIC ENAMEL
IN THE GLASS INTERNAL SIDE

**COMPOSICAO: 82% ESMALTE EM PÓ
E 18% E CERA TERMOFLUIDA**
APPLY THERMOPLASTIC ENAMEL
IN THE INTERNAL SIDE

**INDICE DE TRANSMISSAO UV:
0,10% MAXIMO**
UV TRANSMISSION INDEX: MAXIMUM 0,10%

COLORACAO: PRETO
COLOR: BLACK

MATERIAL: VIDRO TEMPERADO LAPIDADO
MATERIAL: LAPIDATED TEMPERED GLASS

COR E TRANSPARENCIAS:
FUMEE TRANSPARENCIA 50% MINIMO
INCOLOR TRANSPARENCIA 70% MINIMO
VERDE TRANSPARENCIA 70% MINIMO
FUMEE 50% MINIMUM TRANSPARENCY
COLORLESS 70% MINIMUM TRANSPARENCY
GREEN 70% MINIMUM TRANSPARENCY

Tolerâncias dimensionais para vidros temperados e laminados (mm)

Medidas externas	Medidas internas	Medidas de furos
±0,5	±1	±0,5
±1	±2	±1
±2	±3	±2
±3	±4	±3
±4	±5	±4



Scale:	1:10	Date:	12/04/2021
View System:		Liquid weight(Kg):	0,548
Origin:	11810924		
Version:	AA		

Denomination:
VIDRO DA PORTA
DOOR GLASS
VIDRIO DE LA PUERTA

Project Office: ENO_MPIO	Use:	Code:	11835316
Reviser by SAP WorkFlow VIEW IN PLM SYSTEM	Drawer: ALISSOBS	Class:	172425