

Number	Date	Modification	E	Owner
500000294154	28.8.17	ATUALIZAÇÃO GRÁFICA		SCHEILBI

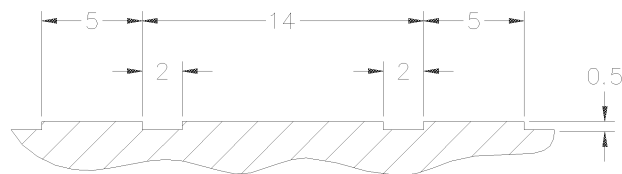
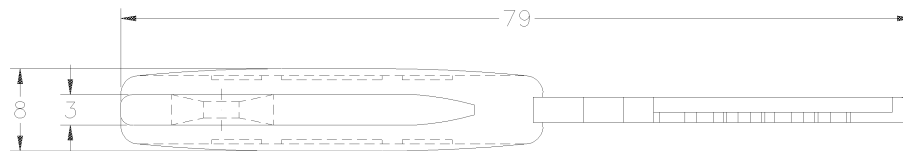
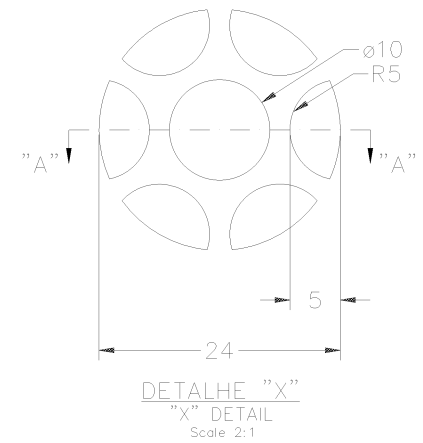
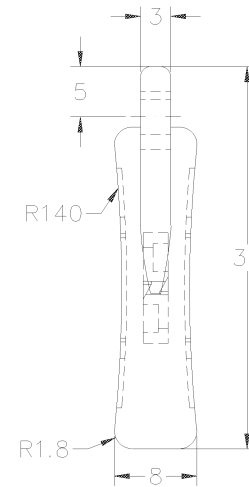
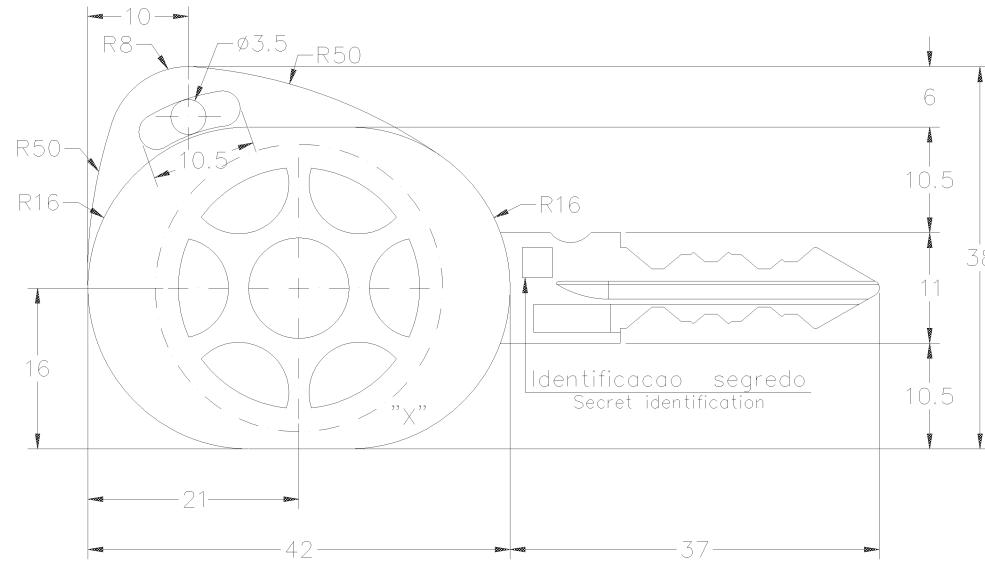

SECCAO "AA"  
"AA" SECTION  
Scale 4:1

Material:  
Material:  
Polietileno baixa densidade  
Low-density polyethylene  
Cor preto  
Color: Black

10175852	820	PADRÃO CLIENTE
11149480	816	MAN
11149449	815	AGRALE
11149448	814	IVECO
10154393	813	VOLKSWAGEM
10154391	812	VOLVO
10154298	811	SCANIA
10154294	810	MERCEDES
CODIGO/CODE	CODIGO SEGREDO/SECRET CODE	USO/USE

	Scale: 2:1	Date: 28.8.17	Denomination:  CHAVE Key Llave
	View System:	Liquid weight: 0,080	
	Origin: 99090204		
	Version: AD		
Project Office: ENO_MP10	Use:		Code: Computer Aided Design
Reviser: SAP WorkFlow:			10154294
View in PLM System			Class: 990917
Drawer: SCHEILBI			

Tolerâncias quando não especificadas  
500 conforme DIN ISO 2768-1 classe m = 76-610  
Verer mit anderen Abtiefen, tolerâncias mit be in accordance with DIN ISO 2768-1 class m = 76-610

Dimensão	0,5 - 3	3 - 6	6 - 30	30 - 120	120 - 400	400 - 1000	1000 - 2000	2000 - 4000
Densidade	± 0,1	± 0,2	± 0,3	± 0,5	± 0,8	± 1,2	± 1,6	± 2
Comprimento	± 0,1	± 0,2	± 0,3	± 0,5	± 0,8	± 1,2	± 1,6	± 2
Raios	± 0,2	± 0,3	± 0,5	± 1	± 1,5	± 2	± 3	± 4
Angulo	± 10'	± 15'	± 20'	± 30'	± 45'	± 1,0	± 1,5	± 2