

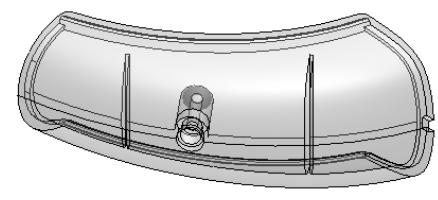

Number	Date	Modification	E	Owner
500000112159	05/12/2012	COTA DE 12 MM NA TORRE ERA 22 MM.		RODRIGD
500000334175	24/04/2018	ALT. DETALHE SECÇÃO CC		MARCOCER

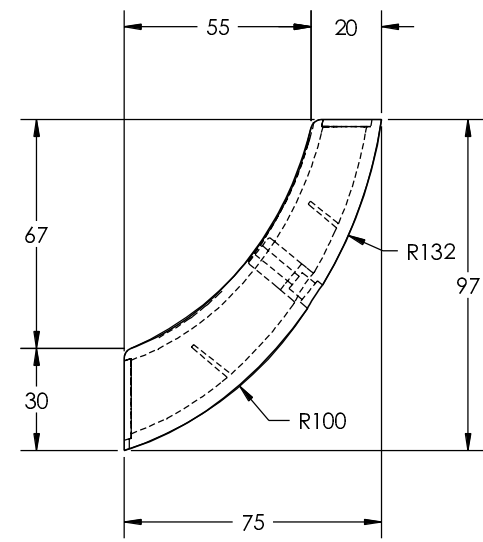
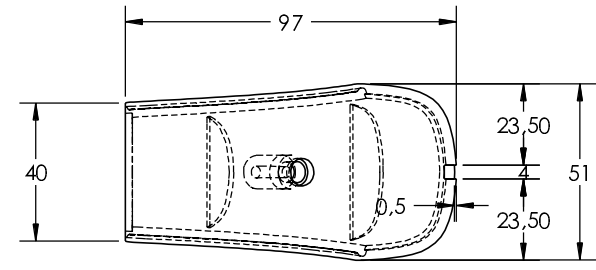
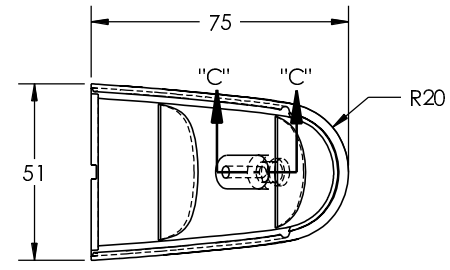
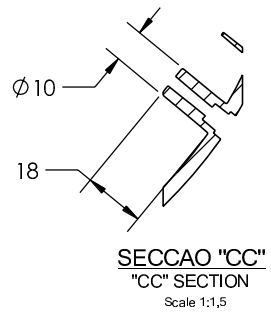

Tolerâncias quando não especificadas:  
500 conforme DIN ISO 2768-1, classe m = médio  
ou as tolerâncias especificadas em desenhos sob RZ, ZP ou L, das m = médio

Dimensões	0,5 - 3	3 - 6	6 - 30	30 - 120	120 - 400	400 - 1000	1000 - 2000	2000 - 4000
Comprimento	±0,1	±0,15	±0,2	±0,3	±0,5	±0,8	±1,2	±2
Diâmetro	±0,05	±0,07	±0,1	±0,15	±0,2	±0,3	±0,5	±0,8
Raio	±0,05	±0,07	±0,1	±0,15	±0,2	±0,3	±0,5	±0,8

**COR: EVO\_2**  
COLOR:  
COLOR:  
**LADO: INTERNO**  
SIDE:  
LADO:  
**MATERIAL: PLAST\_ABS+PC**  
MATERIAL:  
MATERIAL:  
**PROCESSO DE FABRICACAO: INJETADO**  
MANUFACTURING PROCESS:  
PROCESSO DE FABRICACION:

ITEM	CODE	QTY
------	------	-----

	Scale: 1:1,5	Date: 24/04/2018	<b>SUPORTE PEGA-MAO</b>  HANDHOLD SUPPORT SOPORTE PASAMANO
	View System:	Unit weight(kg): 0,033	
	Origin: 10257679		
	Version: <b>AE</b>		
Project Office: ENO_MPI0 Reviser by: SAP Workflow View in PLM SYSTEM Drawn: MARCOCER	Use:	Cod e: <b>10257694</b> <small>Class: 123594</small>	